



**PRINCE 7000 – 4 Point  
ELECTRONIC STRINGING MACHINE  
OWNER'S MANUAL**



Prince Global Sports  
3280 Peachtree Road NE, Suite 2000  
Atlanta, Georgia 30305  
United States of America

# TABLE OF CONTENTS

<b>COMPONENTS</b>	.....	<b>3 &amp; 4</b>
<b>ASSEMBLY INSTRUCTIONS</b>	.....	<b>5 &amp; 6</b>
<b>MOUNTING THE FRAME</b>	.....	<b>7</b>
<b>KEYBOARD FUNCTION</b>	.....	<b>8</b>
<b>MAINTENANCE TIPS + WARRANTY</b>	.....	<b>9 &amp; 10</b>

# Components

Remove all parts from the shipping container carefully.  
Save the container and packing for future storage or shipment.

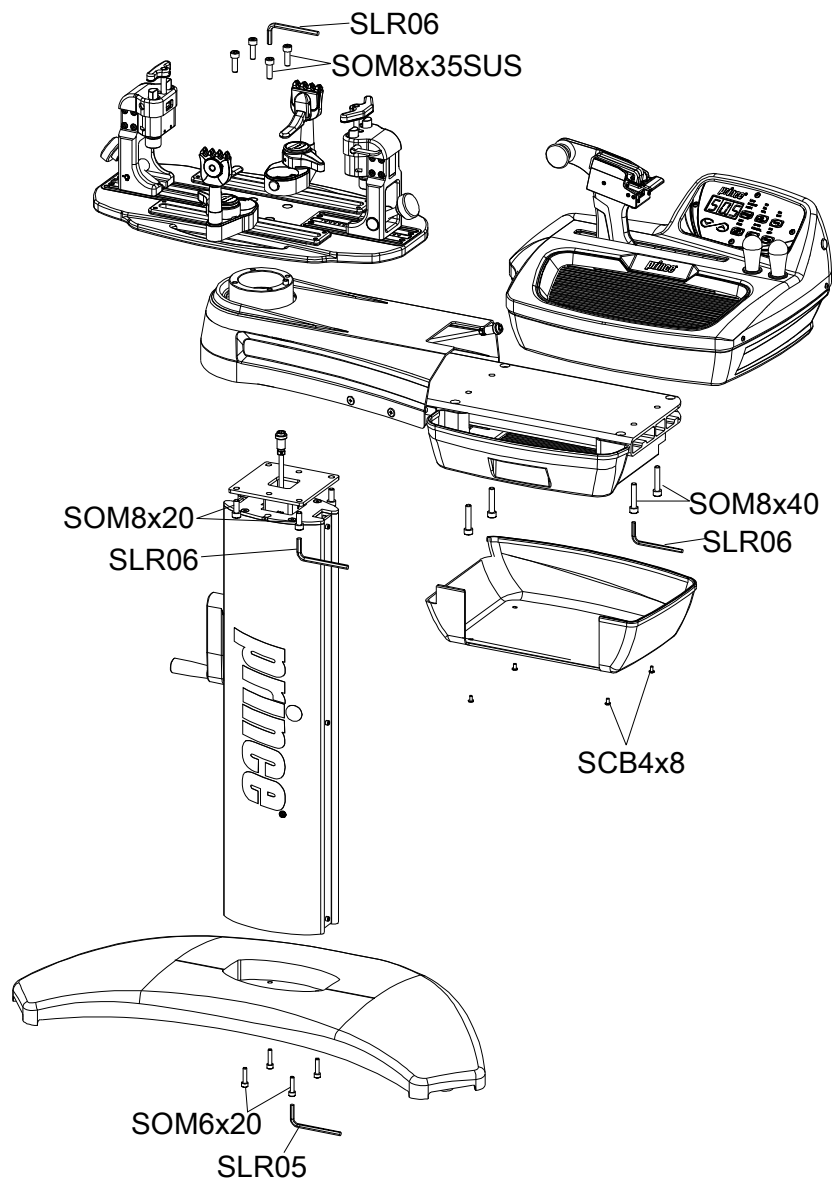



From left to right:

1. Parallel Plier
2. String Bed Cutter
3. Awl
4. Straightening Awl
5. Starting Clamp
6. Screw Driver for Calibration
7. Cutter

4-point Racquet Holders



**Top :**

**Bottom :**

Tennis clamps

Squash / Badminton clamps



# ASSEMBLY INSTRUCTIONS



- A.** Attach bottom Plate to the Stand with 4 screws with 5mm Allen wrench. Use screws attached to the Stand.
- B.** Attach white Power connection to the plug in of the Stand.
- C.** Turn around fully mounted Stand.



- D.** Position the Platform over the center of the stand. Guide Power Cable through center hole.
- E.** Once the Platform is centered on center of the Stand, secure it with 4 cap screws (8mm x 20mm) using 6mm L-shaped Allen wrench.
- F.** Remove cover on the bottom of the Platform. 4 screws need to be removed with screw driver.



- G.** Put Tension Head on the Platform. Connect 2 cables with the plug ins of the Tension Head. Fix screw by hand of each cable connector
- H.** Shows second cable that need to be connected.
- I.** Slide in the Tension Head onto the platform until it sits flat on the Platform.



- J.** Fix the Tension Head to the Platform with 4 screws using 6mm L-shaped Allen wrench.
- K.** Fix the bottom cover which has been removed under F with 4 screws and screw driver.
- L.** Put the Mounting Table onto the Platform and fix with 4 screws while using the 6mm L-shaped wrench



- M.** Plug In the Power Plug at the bottom of the Stand.
- N.** Push the Power Button at the Tension Head. If everything is connected the Power Button will turn on the machine and show a green light. Display will turn on too.
- O.** Use Power Plug (Black Button on the Bottom of the Stand) on the side for LED lights at the Stand. The crank on side of the Stand will adjust the height. The crank is removable.

## Mounting a frame



**A**

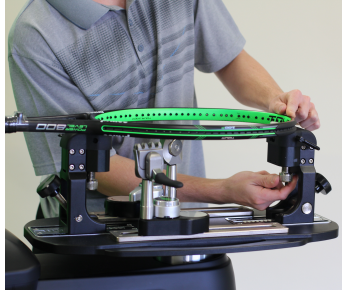

**B**

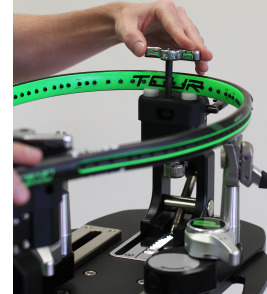

**C**

- A.** Put the racquet on the 2 Mounting towers and adjust the spacing with outside screws to the size of the inside head size. White holders on the inside need to sit at the frame.
- B.** Adjust the height of inside racquet holders close to the grommets, they should not touch the grommets or even squeeze them. This has to be done on both sides of the racquet/
- C. & D.** Add the racquet holder from the top and fix the frame in pushing down the side leveler.



**D**

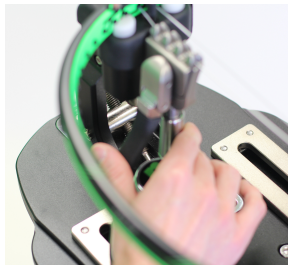

**E**



**F**

- E.** Use the clamps to keep the tension on each string. Use Tennis specific clamp for Tennis racquets, use Squash/Badminton clamp for those frames
- F.** Adjust the white contact pad height by turning the knob directly below the pads. The pads should contact the frame just below the string holes or grommets for maximum support.
- G.** Fix clamp base after every tension pull to make sure clamp base does not move and to keep the tension.
- H.** Use 2 awl holder for the Awl and straightening AWL



**H**

## Display Functions



- LBS / KGS :** Select kgs or lbs by pressing the **LBS/KGS** button for 3 seconds to switch.
- TENSION :** Adjust the tension setting by pressing the ↑ and ↓ arrows on the control panel.
- SPEED OF PULL :** Select **LOW/MED/HIGH** by pushing the SPEED button. It is recommended to use the low speed with low elongation strings such as Kevlar, or strings of a more fragile nature such as natural gut. The medium speed is well suited for polyester type strings, and the high speed is suited for nylon based string types.
- PRE-STRETCH :** The amount the machine pulls beyond the desired tension before setting back to that tension. Many stringers like to pre-stretch strings to reduce the amount of tension loss. Select the amount of pre-stretch by pushing the **PRE-STRETCH** button.
- KNOT :** Press the Knot Button to have the machine making one pull with +10% increased tension
- MUTE :** Press the Mute Button if you do not want to hear the BEEP sound while pulling the tension
- BRAKE :** Press the Brake button for 3 sec. to switch between automatic or manual break. Automatic means that with every tension pull the break will lock. Manual means that the stringer decides by pushing the button when the break locks in.



## Maintenance Tips



### 1. Cleaning the machine

- a. String clamps, string clamp rails, and speed jaws must be cleaned regularly with alcohol to minimize string slippage.
- b. If the string clamp base slips after cleaning rails turn the base adjustment screw 1/8 turn clockwise using the 3mm L-shaped allen wrench.
- c. **Do not over tighten adjustment screw or damage may occur**

### 2. Clamp Maintenance

- a. To improve the life of your clamps, apply a small amount of grease to contact points (picture #2). Open and close the clamp several times to distribute the grease. Wipe off any excess grease before stringing.
- b. Periodically check the 2 points to insure they remain greased. Apply grease to clamp post, then wipe gently with a dry cloth leaving a thin film of grease on the surface. The lubricated surface ensures a smooth operation and provides rust protection.

3. To calibrate the machine, remove the knob on the right side of the Tension Head / Display. Use screw driver out of the tool kit to adjust the correct pulling tension. Additionally needed is a pulling scale that is not delivered with the machine.

**AS WITH ANY MACHINE WITH MOVING PARTS AND ELECTRONIC POWER, SIGNIFICANT INJURY CAN OCCUR IF PROPER CARE IS NOT EXERCISED WHEN USING THE PRINCE 7000 STRINGING MACHINE. THIS MACHINE IS ONLY TO BE UTILIZED IN STRICT COMPLIANCE WITH THE INSTRUCTIONS SET FORTH**

IN THIS MANUAL.

## Warranty contacts

For all service and warranty questions please contact:

**Western Hemisphere:**

**Tennis Machines Sales & Services**

**8131 Delmar Blvd**

**University City, MO 63130**

**800-572-1055**

[jc@tennismachines.com](mailto:jc@tennismachines.com)

<http://www.tennismachines.com>

**Eastern Hemisphere:**

**Prince Global Sports International**

**Hill Place House 2<sup>nd</sup> Floor**

**55A High Street**

**Wimbledon Village SW19 5BA**

**United Kingdom**

**??@princeglobalsports.com**